

KUBOTA WHEEL LOADER

RT210-2

For Earth, For Life

Kubota



Engine output:
26 HP / 19 kW



Machine weight:
2100 / 2213 kg

Standard equipment

Kubota Engine D1105 Stage V

Tyres 10.0/75x15.3 AS (Total width 108 cm)

Hydrostatic Transmission 4 wheel drive with automotive control

6 ton axles (HD version) with 14.300 N pulling force

Limited slip on both axles

Electric shuttle on joystick

Lifting arm and tilt controlled by joystick

Double acting mechanical auxiliary circuit AUX1

Floating position

ROPS / FOPS canopy incl. safety doors

Deluxe seat with safety belt, armrest and extended backrest

Battery main switch

Towing hook at the back

Working light (halogen) front and on lifting arm

Cyclone filter

Oil Cooler

Hydraulic quick coupler

Drum brakes



Specifications

Model name		RT210-2	
Engine	Make	Kubota	
	Model	D1105	
	Displacement	CC	1123
	Output	HP(kW)	26 (19)
Service weight		kg	2100
Lifting capacity in straight position		kg	1450
Driving speed	1°st speed	km/h	0~10
	2°nd speed	km/h	0~20
Tipping load	A	kg	2000
	B	kg	1250
	C	kg	950
Auxiliary circuit	Oil flow	l/min	45
	Oil pressure	bar	170



Dimensions

Model name		RT210-2	
A	Wheel base	mm	1515
B	Overall length	mm	2975
C	Overall height with canopy	mm	2300
C'	Overall height with cabin	mm	2284
D	Overall width	mm	1080/1280
E	Height front frame	mm	1480
F	Max. dumping height	mm	1988
G	Max. bucket pin height	mm	2825
H	Height with bucket	mm	3392

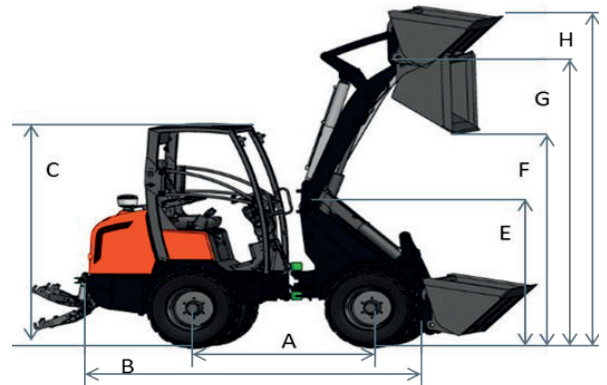

Accessories



Earth bucket



Bucket 4 in 1

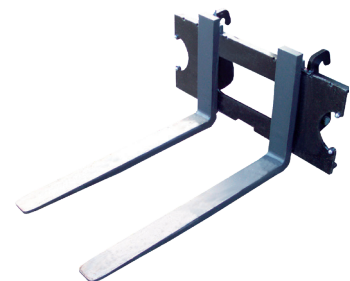

Pallet fork



KUBOTA EUROPE S.A.S.

19 rue Jules Verceyruisse
 Zone Industrielle - CS 50088
 95101 Argenteuil Cedex France
 Téléphone : (33) 01 34 26 34 34
 Télécopieur : (33) 01 34 26 34 99
<http://www.kubota-eu.com>